

HYUNDAI
POWER PRODUCTS

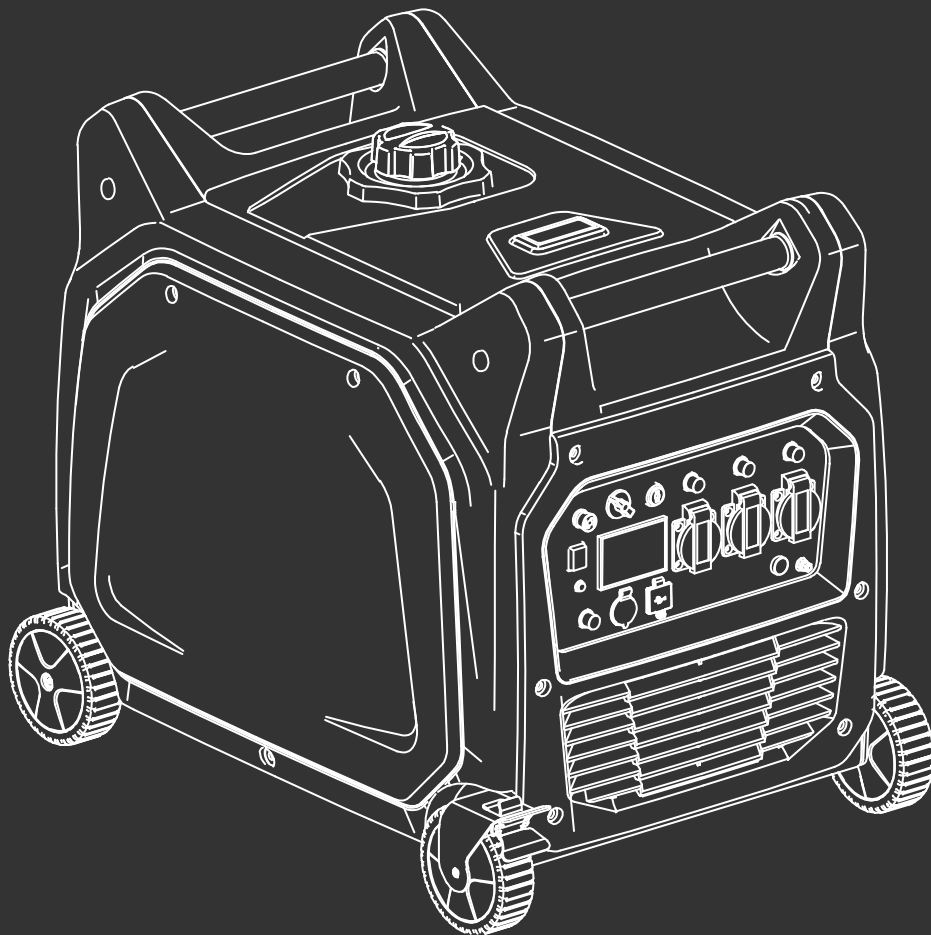

INVERTER GENERATOR **HY6500SEi**

Instruction Manual



Introduction

Thank You For Purchasing Your HYUNDAI Product

We work very hard to give all of our customers the best possible service. If you have any problems, before leaving negative feedback, please contact us to give us a chance to resolve the issue. We would be delighted if you left us positive feedback! Thank you for purchasing this product.

Important!



⚠WARNING : READ THE INSTRUCTION BOOKLET THOROUGHLY BEFORE USING THE MACHINE. Keep for future reference and pass it on if the machine is loaned or sold to another user.

This manual has been produced by Hyundai Power Products and should be kept with the product. Please read and understand these instructions before you use your product. Failure to do this may result in personal injury or damage to the product.

The safety precautions and warnings are to ensure your safety and protect you from harm or damage to the product.

The information contained in this manual was accurate at the time of production, however HYUNDAI Power Products may make modifications to the product without notification.

Contents

Safety Information.....	4-15	Recycling And Disposal.....	48
Symbols On The Machine.....	4	Notes.....	49-51
Intended Use.....	5	Our Product Range.....	52
Understand Your Machine.....	6	Useful Information.....	53
Personal Safety.....	6-7	Contact Us.....	54
Inspect Your Machine.....	7	Product Information.....	55
Work Area.....	8		
During Use.....	8		
Engine Safety.....	9		
Carbon Monoxide.....	10		
Electrical Safety.....	11		
Batteries.....	11		
Vibrations.....	12		
Noise.....	12		
Personal Protective Equipment.....	13		
Fuel Safety.....	14-15		
Features.....	16-21		
Wiring Diagram.....	22		
Unboxing.....	23		
Pre-Operation Checks.....	24-26		
Check Engine Fuel.....	24		
Check Engine Oil.....	25		
Ground (Earth).....	26		
Connect Battery.....	26		
Before Each Use.....	27		
Operation.....	28-33		
Starting The Engine.....	28-29		
Using Electric Power.....	30-32		
Stopping The Engine.....	33		
Maintenance.....	34-41		
Maintenance Safety.....	34		
Cleaning.....	35		
Transportation.....	35		
Maintenance Chart.....	36		
Engine Oil Replacement.....	37		
Air Filter.....	38		
Cleaning And Adjusting Spark Plug.....	39		
Fuel Tank Filter.....	40		
Muffler Screen.....	41		
Storage.....	42-43		
Troubleshooting.....	44		
Technical Data.....	45-46		
Specification.....	45		
Spare Parts.....	46		
Declaration Of Conformity.....	47		

Contact Us



www.hyundaipowerproducts.co.uk



01646 687 880



aftersales@hyundaipowerproducts.co.uk

Safety Information

Symbols On The Machine

We have provided safety messages in this manual and on the machine. This information alerts you to potential hazards that could hurt you or others. Please read these messages carefully. However, we may not have listed all of the possible hazards, you must also use your own judgment.

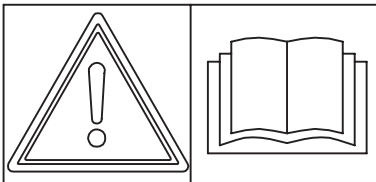

IMPORTANT

Please read this instruction manual carefully, especially the safety warnings marked with the symbol. Read and understand operator's manual before using the machine. Failure to follow instructions could result in death or serious injury.

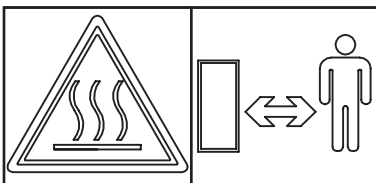

DANGER

Hot surfaces. Keep away from exhaust.

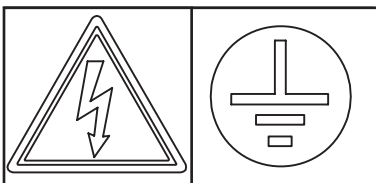

DANGER

Risk of electric shock.
Earthing point.

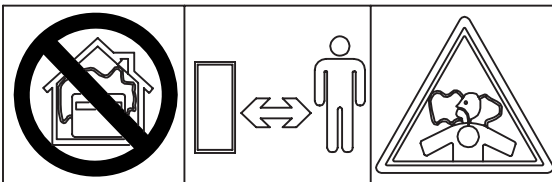

CARBON MONOXIDE

Never operate the engine indoor or in areas with poor ventilation. The exhaust gas from the engine contains carbon monoxide.

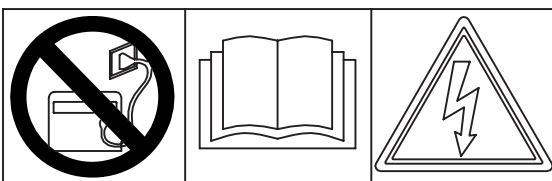

DANGER

Do not back feed into the mains supply.



CE SYMBOL

This product complies with the applicable European directives and an evaluation method of conformity for these directives was done.

Safety Information

Intended Use

The HY6500SEi is a petrol powered inverter generator from HYUNDAI. The HY6500SEi is powered by a 389cc 4-stroke OHV petrol engine.

The generator is manufactured according to the latest safety requirements. Every precaution is only effective when it is followed exactly.

User Types

This machine is intended for use by consumers, i.e. non professional operators. The machine is intended for “DIY” and domestic use only.

Improper Use

Examples of improper use may include, but are not limited to:

- use in a marine environment
- use as permanent sole source of power

For full specification, go to page 45 or visit www.hyundaipowerproducts.co.uk



Safety Information

⚠ Understand Your Machine

- **WARNING!** You must read these instructions carefully before operating the machine. Make sure that you are familiar with the controls and properly operate the machine. You must learn how to stop the machine quickly. If you do not follow the warnings and instructions, it may result in fire and/or serious injury. Make sure to save all warnings and instructions for future reference.
- Read this manual and labels affixed to the machine to understand its limitations and potential hazards.
- Be thoroughly familiar with the controls and their proper operation. Know how to stop the machine and disengage the controls quickly.
- If the unit is to be used by someone other than original purchaser, or is to be loaned, rented, or sold, always provide this manual and any needed safety training before operation. The user can prevent and is responsible for accidents or injuries that may occur to themselves, to other people, or to property.
- Do not force the machine beyond its limits. Use the correct machine for your application.
- Know how to stop the machine quickly in case of emergency. Understand the use of all controls.
- ALL MAINTENANCE other than that listed in this manual, should be carried out by professionally trained and certified personnel.

⚠ Personal Safety

- **WARNING!** Never allow children or people unfamiliar with these instructions to use the product. Local regulations can restrict the minimum age of the operator.
- Keep children, pets, and other people not using the unit away from the work area. Be alert and shut off the unit if anyone enters work area. Keep children under the watchful care of a responsible adult.
- Stay alert, watch what you are doing and use common sense when operating the machine. Never operate the machine when unwell or tired, or if you have taken alcohol, medicine, drugs or any substances which may slow your reflexes and compromise judgment. A moment of inattention while operating the machine may result in serious personal injury.
- Appropriate Personal Protective Equipment (PPE), **MUST** be worn at all times when operating or repairing the machine. Always wear anti-slip and resistant work footwear and long trousers while using the machine. Do not use the machine when barefoot, wearing sandals or similar lightweight footwear. Do not wear chains, bracelets or clothing that is loose fitting or hanging ties or cords. Tie long hair back. Always wear protective earplugs. Loose clothes, jewellery, or long hair can be caught in moving parts. Protect eyes, face, and head from objects that may be thrown from the unit. Always wear safety goggles or safety glasses with side shields when operating.

Safety Information

- Always keep hands and feet away from all pinch points.
- Do not touch parts that might be hot from operation. Allow parts to cool before attempting to maintain, adjust, or service.
- Never place any part of your body where it would be in danger if movement should occur during assembly, installation, and operation, maintenance, repairing or moving.
- Keep in mind that the operator or user is responsible for accidents, hazards or unexpected events involving the machine that occur to other people or their property. It is the responsibility of the user to assess the potential risk of the area where work is being carried out. The operator or user must take all necessary precautions to ensure their own safety and that of others, especially on slopes or rough, slippery and unstable ground.

⚠ Inspect Your Machine

- Check your machine before starting it. Keep guards in place and in working order. Make sure all nuts, bolts, etc., are securely tightened.
- You must check the general condition of the machine before use.
- Never operate the machine when it is in need of repair or is in poor mechanical condition. Replace damaged, missing, or failed parts before using it. Check for fuel leaks. Keep the machine in safe working condition.
- Do not use the machine if the engine's switch does not turn off the engine when running. Any petrol powered machine that can't be controlled with the engine switch is dangerous and must be replaced.
- If the machine should start to vibrate abnormally, stop the engine and check immediately for the cause. Vibration is generally a warning sign of trouble.
- Avoid accidental starting. Be sure the engine's switch is off before transporting the machine or performing any maintenance or service on the unit. Transporting or performing maintenance or service on a machine with its switch on invites accidents.
- Do not tamper with or disable safety systems. Only use manufacturer-recommended attachments.
- Before using, always visually inspect to see that the tools are not worn out or damaged. Replace worn out or damaged elements and bolts.
- Keep all nuts, bolts and screws tight to ensure the equipment is in safe working condition.
- Keep the machine in good operating condition. Operating the machine in poor or questionable condition could result in serious injury.
- Be sure all safety devices are in working order and warning labels are in place. These items are installed for your safety.



Safety Information

⚠ Work Area

- You must only work in daylight or with good artificial light in good visibility conditions. Keep people, children and animals away from the working area.
- Operate on flat, level ground.
- Never park the machine in a place with unstable ground which could give way.
- You must be careful near ravines, ditches or embankments.
- Do not work in the rain or when there is a thunderstorm or lightning risk. If there is bad weather conditions, do not use the machine.

⚠ During Use

- **WARNING!** If something breaks or an accident happens whilst working, you must turn off the engine immediately and move the machine away to prevent further damage. If an accident happens with injuries or third parties are injured, carry out the first aid measures most suitable for the situation immediately and contact the medical authorities for any necessary health care. Carefully remove any debris that might cause damage or harm persons or animals should it not be seen.
- Never attempt to move the machine in any way other than intended for normal use while the engine is running.
- Place the machine in a place where pedestrians or children are not likely to touch the machine.
- Avoid placing any flammable materials near the exhaust outlet during operation.
- Keep the machine at least 1m (3 ft) from buildings or other equipment, or the engine may overheat.
- Avoid operating the engine with a dust cover.
- Put the machine on the flat ground, for the machine eliminating heat freely.
- Never touch the machine with wet hands or electrical shock will occur.
- Be sure to ground (earth) the generator.
- Do not use in a vehicle.

Safety Information

⚠ Engine Safety

- This machine is equipped with an internal combustion engine. Do not use on, or near, forest-covered or brush-covered land unless the exhaust system is equipped with a spark arrester meeting applicable local, state, or federal laws.
- A spark arrester, if used, must be maintained in effective working order by the operator.
- Never start or run the engine inside a closed area. The exhaust fumes are dangerous, containing carbon monoxide, an odourless and deadly gas. Operate this unit only in a well-ventilated outdoor area. (See carbon monoxide safety).
- Do not tamper with the engine in an effort to get it to run at higher speeds. The maximum engine speed is preset by the manufacturer and is within safety limits.
- Keep a fire extinguisher on hand when operating this machine in dry areas as a precautionary measure.
- Never leave the operating position when the engine is running.
- The engine parts get very hot when running, do not touch. Danger of burns.
- Follow the instructions to ignite the engine carefully whilst keeping feet away from moving parts.
- Never incline the machine during ignition. Ignite the machine on a flat surface without obstacles or high grass.
- Do not over-rev the engine or change the engine settings.
- Never pick up or carry the machine while the engine is running.
- Stop the engine whenever you leave the machine, or before refuelling, when cleaning or while maintaining.
- Reduce the throttle setting during engine shut down and, if the engine is provided with a shut-off valve, turn the fuel off at the conclusion of working.
- Do not tilt the machine when starting the engine.



Safety Information

⚠ Carbon Monoxide



Engine exhaust fumes contain Carbon Monoxide. This is a poisonous gas and can kill in minutes. **NEVER** use inside a building or in an area with poor ventilation. **NEVER** use inside a confined space, such as but not limited to a house, garage, vehicle, boat or tent. **ONLY** use outside and far away from windows, doors and vents. Read the user manual before operating.

⚠ DANGER!

Engine exhaust fumes contain Carbon Monoxide. This is a poisonous gas and can kill in minutes. **NEVER** use inside a building or in an area with poor ventilation. **NEVER** use inside a confined space, such as but not limited to a house, garage, vehicle, boat or tent. **ONLY** use outside and far away from windows, doors and vents.

CARBON MONOXIDE IS A COLOURLESS, ODOURLESS GAS. INHALING THIS GAS CAN CAUSE DEATH OR SERIOUS LONG-TERM HEALTH PROBLEMS SUCH AS BRAIN DAMAGE.

Never operate the engine in a confined space where dangerous carbon monoxide fumes can develop. All ignition operations have to be effected in an open or well-ventilated area. Always remember that exhaust fumes are toxic.

The symptoms of carbon monoxide poisoning can include but are not limited to the following; Headaches, dizziness, nausea, breathlessness, collapsing or loss of consciousness.

Carbon monoxide poisoning symptoms are similar to flu, food poisoning, viral infections and simply tiredness. It is quite common for people to mistake this very dangerous poisoning for something else.

To avoid carbon monoxide poisoning **DO NOT** use Petrol/Diesel powered equipment inside any of the following; Home, garage, tent, camper van, mobile home, caravan or boat. **DO NOT** use in an enclosed area or moving vehicle. This is not exhaustive and if you are in any doubt contact your dealer.

If you think you have or someone around you has been affected by carbon monoxide poisoning; Get them fresh air immediately, by leaving the affected area or by opening doors and windows. If safe and practical to do so make sure that the machine is turned off. **DO NOT** enter a room you suspect of having carbon monoxide present – instead call the emergency services.

Contact a Doctor immediately or go to Hospital – let them know that you suspect carbon monoxide poisoning.

Safety Information

⚠ Electrical Safety (Where Applicable)



DANGER!

ELECTRICITY CAN KILL - NEVER WORK ON LIVE/ENERGISED EQUIPMENT.

- Prior to carrying out any maintenance work you **MUST** identify electrical isolation methods and isolate all electrical supplies.
- Prior to use and with all electrical supplies isolated, you **MUST** check all electrical cables, plugs and connectors for the following;
 - Are intact and have no signs of damage, to include but not limited to bare wires, chaffing, cuts and loose wiring.
 - If there are any signs of damage, the damaged item **MUST** be taken out of service until the damage has been repaired by an electrically competent person.
 - All trailing cables should be routed so as not to cause any kind of trip hazard.
 - **NEVER** work on or near electricity with wet hands, wet clothing and wet gloves.

⚠ Batteries (Where Present)

Batteries present a risk if they become damaged by the possible leaking of electrolyte. This electrolyte is an acid and can cause serious burn injuries. Care should be taken when working on or near them. **NOTE** the electrolyte may be in a liquid or gel form.

Should you come in to contact with electrolyte you should;

- Remove all clothing contaminated with electrolyte. If you cannot remove then saturate them in water.
- Get medical assistance as soon as possible.

You must advise the medical staff of the type of acid.

- Lead/acid battery = dilute sulphuric acid.
- Nickel/cadmium = potassium hydroxide alkali electrolyte.
- Use fresh running water to wash off excess electrolyte, continue this until medical assistance arrives. Make sure that you do not wash the electrolyte to another part of your body or face.
- If electrolyte comes in to contact with Eyes the electrolyte needs to be immediately washed away with large amounts of water. Make sure that you do not wash the electrolyte to another part of your face or body.
- Gasses from charging batteries are highly flammable and great care should be taken to charge in well ventilated areas.



- There is an explosion risk if the battery terminals are short circuited, when connecting/disconnecting **ALWAYS** exercise great care so that the terminals or battery leads are **NOT** allowed to touch and cause a spark. **ALWAYS** use suitable insulated tools.

Contact Us



www.hyundaipowerproducts.co.uk



01646 687 880



aftersales@hyundaipowerproducts.co.uk

Safety Information

⚠ Vibrations (Where Applicable)

- Prolonged use of hand held (operated) machines will cause the user to feel the effects of/from vibrations. These vibrations can lead to white finger (Raynaud's phenomenon) or carpal tunnel syndrome. This condition reduces the ability of the hand to feel and regulate temperature, causing numbness and heat sensations and may cause nerve damage and circulatory tissue death.
- Not all factors that lead to white finger disease are known, but cold weather, smoking and other diseases that affect blood vessels and blood circulation as well as large and long-lasting impact of shocks are considered factors in the formation of white finger. Note the following to reduce the risk of white finger and carpal tunnel syndrome;
 - Wear gloves and keep your hands warm.
 - Take regular breaks.
 - All of the above precautions may help reduce the risk of white finger disease but not rule out the carpal tunnel syndrome. Long-term and regular users are therefore recommended to observe the condition of your hands and fingers. Seek medical attention immediately if any of the above symptoms should occur.

⚠ Noise (Where Applicable)

- The operating noise of the machine can damage your hearing. When wearing protection such as earplugs or ear defenders to protect your hearing. Long-term and regular users are advised to have hearing checked regularly. Be especially vigilant and cautious when wearing ear protection because your ability to hear alarm warnings will be reduced.
- Noise emissions for this equipment is unavoidable. Carry out noisy work at approved times and for certain periods. Limit the working time to a minimum. For your personal protection and protection of people working nearby it is also advisable for them to wear hearing protection.



- See Certificate of Conformity section for Outdoor Noise declaration of conformity.

Safety Information

⚠ Personal Protective Equipment

Appropriate Personal Protective Equipment (PPE), MUST be worn at all times when operating or repairing the machine. No protective equipment can ensure 100% protection.

When selecting PPE, make sure it's CE marked and it suits the user in terms of size, fit, etc. If more than one item of PPE is worn at the same time, make sure they can be used together, e.g. wearing safety glasses may disturb the seal of a respirator, causing air leaks.



HAND PROTECTION MUST BE WORN

Protective electrically non-conductive gloves are highly recommended when working.



FOOT PROTECTION MUST BE WORN

Non-skid heavy duty footwear are highly recommended when working.



HEARING PROTECTION MUST BE WORN

Suitable safety hearing protection is recommended.



EYE PROTECTION MUST BE WORN

Always wear safety glasses/goggles and/or face shields. Everyday eyeglasses have only impact resistant lenses; they are not safety glasses/goggles.



PROTECTIVE CLOTHING MUST BE WORN

Do not wear loose clothing, gloves, scarfs, neckties or jewellery (rings, wrist watches), which can be caught in moving parts.



HEAD PROTECTION MUST BE WORN

Wear a safety helmet with a safety visor.



FACE SHIELD MUST BE WORN

Wear a face shield to protect your face.



RESPIRATOR MUST BE WORN

Wear a respirator.



Safety Information

⚠ Fuel Safety



CAUTION! ALL FUELS ARE HIGHLY FLAMMABLE AND PETROL VAPOUR IS EXPLOSIVE. TAKE EXTREME CARE WHEN HANDLING FUEL. KEEP FUEL OUT OF REACH OF CHILDREN.

General Safety

- Do not smoke each time fuel is handled.
- ALWAYS avoid inhaling fumes.
- ALWAYS carry fuel in the correct and clearly marked container.
- ALWAYS wear correct, suitable and fit for purpose Personal Protective Equipment (PPE), suggested items are but not limited to safety gloves and overalls.
- To avoid sparking or arcing, keep grounded conductive objects – such as tools – away from exposed, live electrical parts and connections. These events could ignite fumes or vapours.
- Do not operate the machine with known leaks in the fuel system.
- Fire hazard - keep fuel away from all sources of ignition for example heaters, lamps, sparks from grinding or welding.
- DO NOT carry out hot work on tanks that have contained fuel.
- ALWAYS keep the work area tidy.
- ALWAYS dispose of waste fuels correctly.
- Serious personal injury can occur when petrol is spilled on yourself or your clothes. Rinse your skin and change your clothes immediately.

Spilled Fuel

- If you have spilled fuel, make sure you do not attempt to ignite the engine but move the machine away from the area of spilled fuel and avoid creating any source of ignition until the fuel has evaporated and fuel vapours have dissipated.
- When fuel is spilled on yourself or your clothes, wash your skin and change clothes immediately.
- ALWAYS clean up spills promptly using absorbent granules and a lidded bin.

Safety Information

Fuelling / De-Fuelling

- ALWAYS fuel and de-fuel in a well ventilated area outside of buildings. Use a funnel to add fuel, only outdoors. Do not smoke during this and each time fuel is handled.
- Add fuel before igniting the engine, never remove the fuel tank cap or add fuel whilst the engine is running or when it is hot.
- When de-fuelling ALWAYS use a proper fuel retriever.
- Never overfill the fuel tank. Engine heat can cause fuel to expand, never fill the tank to more than 1/2" below the bottom of the filler neck. This will provide space for fuel expansion.
- When refilling or draining the fuel tank, use an approved fuel storage container while in a clean, well-ventilated outdoor area. While adding fuel or operating the unit, do not smoke, and stay away from sparks, open flames, or other sources of ignition near the area of operation.
- Always stop the engine and allow it to cool before filling the fuel tank. Never remove the cap of the fuel tank or add fuel while the engine is running or when the engine is hot.
- Loosen the fuel tank cap slowly to relieve any pressure in the tank.
- ALWAYS keep the handles dry, clean and free of oil and fuel.
- After fuelling, ensure to tighten the cap securely.
- Never use the lock-function when filling with fuel.

Storage

- Store fuel in containers specifically designed and approved for fuel storage.
- Store fuel in a cool, well-ventilated area, safely away from sparks, open flames, or other sources of ignition.
- Never store fuel – or a machine with fuel in the tank – inside a building where fumes may reach a spark, open flame, or any other source of ignition (such as a water heater, furnace, or clothes dryer). Allow the engine to cool before storing in any enclosure.
- Replace all fuel tank and container caps securely and wipe up spilled fuel. Never operate the unit without the fuel cap securely in place.



Features

HY650SEi Features

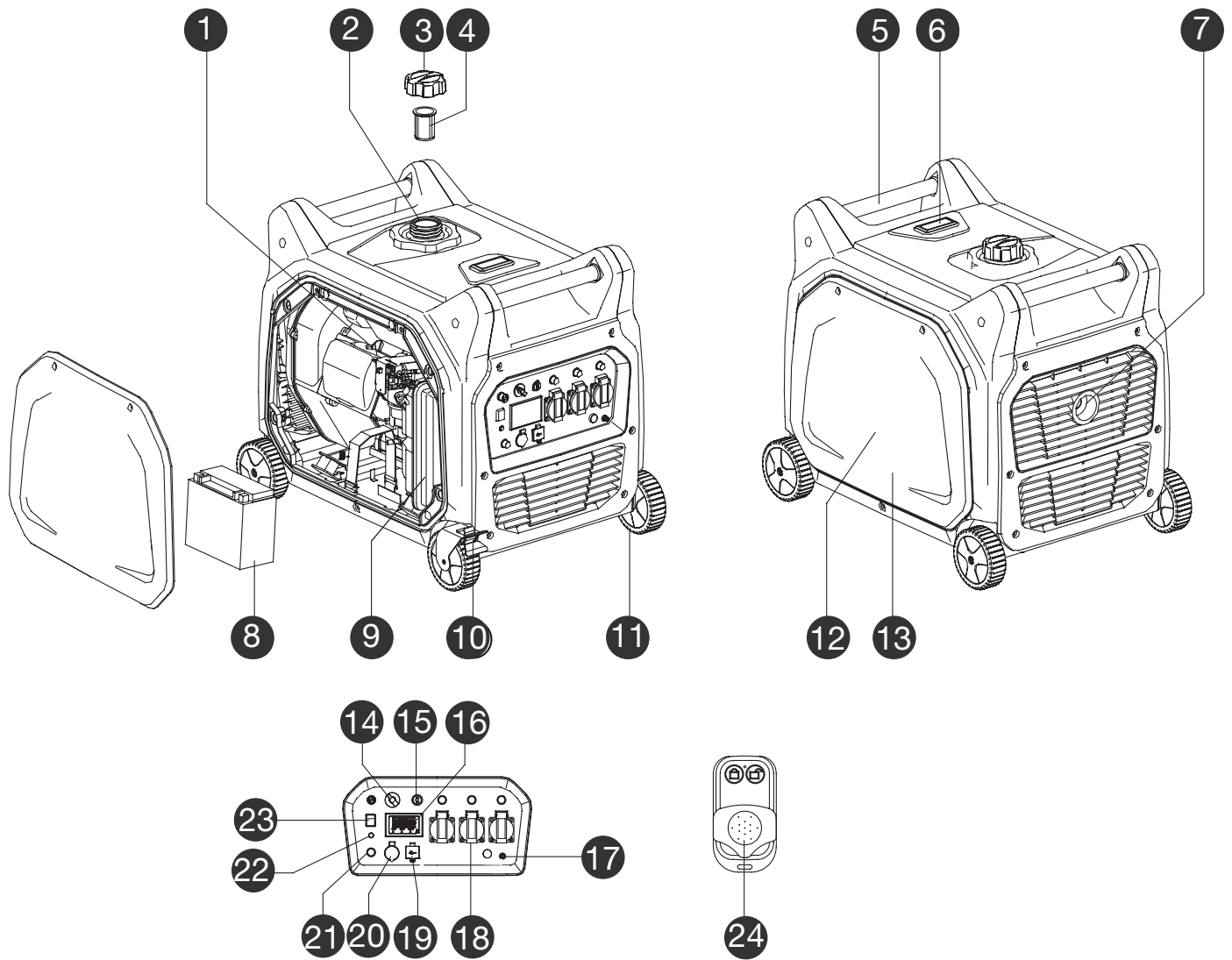

Features

HY6500SEi Features

- 1 Spark Plug
- 2 Fuel Tank
- 3 Fuel Tank Cap
- 4 Fuel Filter
- 5 Carrying Handle
- 6 Fuel Level Gauge
- 7 Muffler
- 8 Battery
- 9 Air Filter
- 10 Brake Lever
- 11 Wheel
- 12 Oil Filler Cap
- 13 Oil Drain Plug
- 14 Fuel Tap
- 15 Engine Switch
- 16 Data Display Instrument
- 17 Ground (Earth) Terminal
- 18 AC Receptacle
- 19 USB Output
- 20 DC 12V Receptacle
- 21 DC Protector
- 22 Output Reset
- 23 Economy Control Switch
- 24 Remote Control



Features

Oil Warning System

When the oil level falls below the lower level, the engine stops automatically. Unless you refill with oil, the engine will not start again. Check oil level daily to ensure oil level is to the upper mark on the dipstick.

Engine Switch

The engine switch controls the ignition system.

- 1 RUN**
The engine can be started.
- 2 STOP**
Ignition circuit is switched off. The engine will not run.
- 3 START**
The starter motor starts the engine.

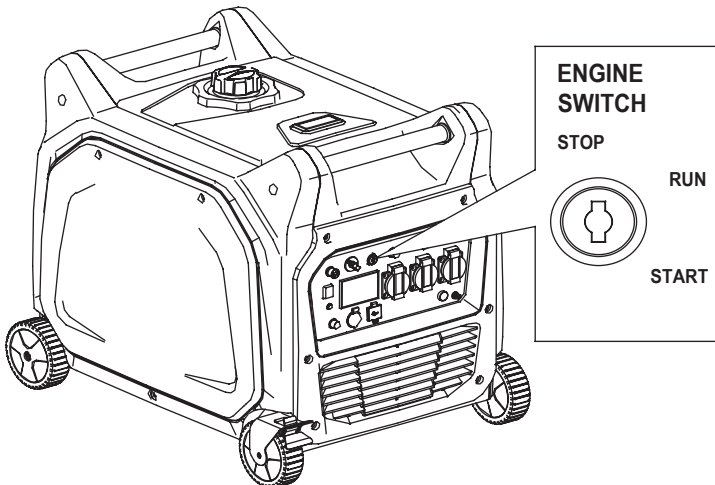

Economy Control Switch

When the economy control switch is turned ON, the engine speed matches the load. The results are better fuel economy and reduced noise.

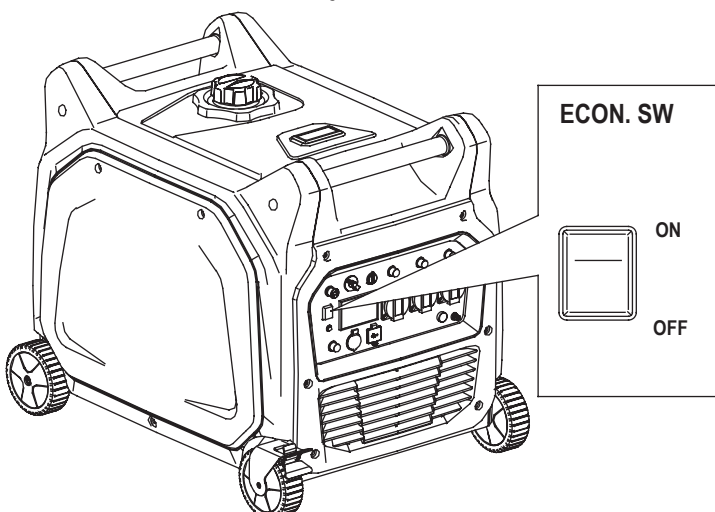

Features

DC Overload Breaker

The DC overload breaker turns off automatically when the load exceeds the generator rated output.

! CAUTION

Reduce the load to within specified generator rated output if the DC overload breaker is off.

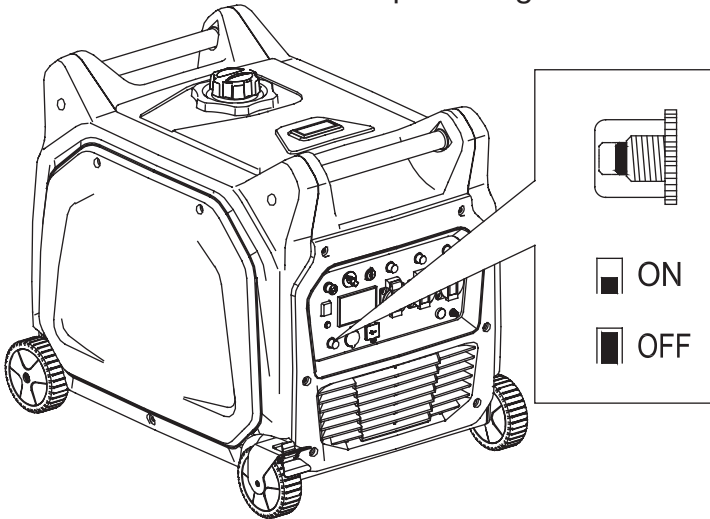

AC Overload Breaker

If overloaded the breaker button will pop out. Push back in to reconnect AC output power.

! NOTE

Please reduce the load of generator to ensure that the total load is within the rated power.

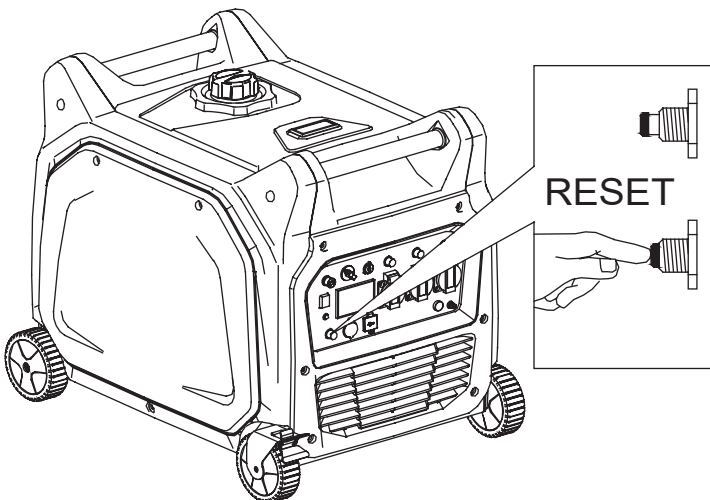

Features

Remote Control Switch

The remote control switch controls the ignition system.



Push to start.



Push to stop.

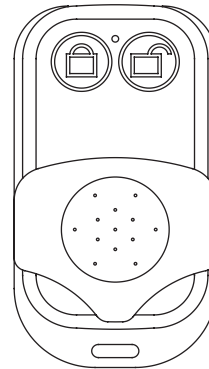

Brake Lever

The function of brake lever is preventing generator moving.

- 1 Release brake to move generator.
- 2 Push brake down when in use.

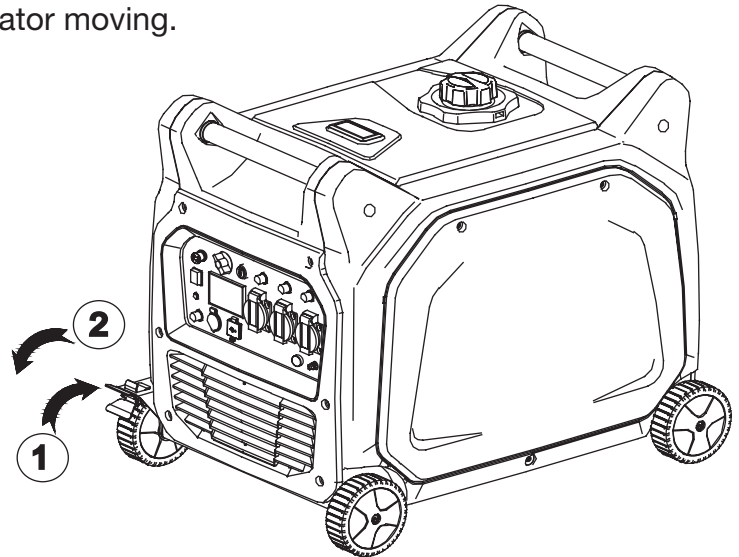

Fuel Tap



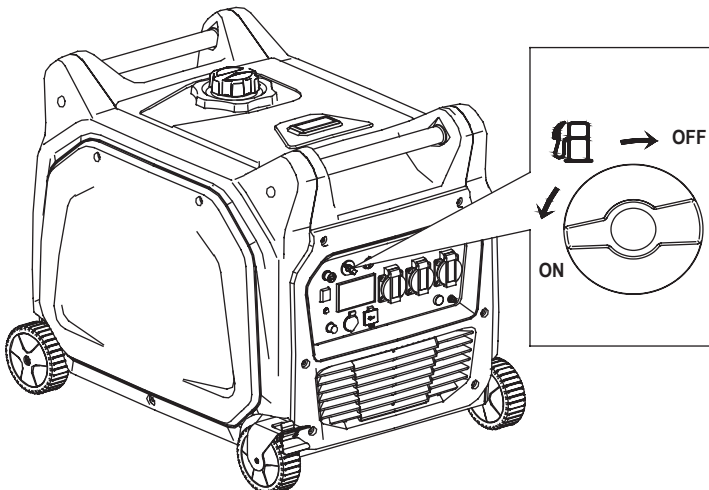





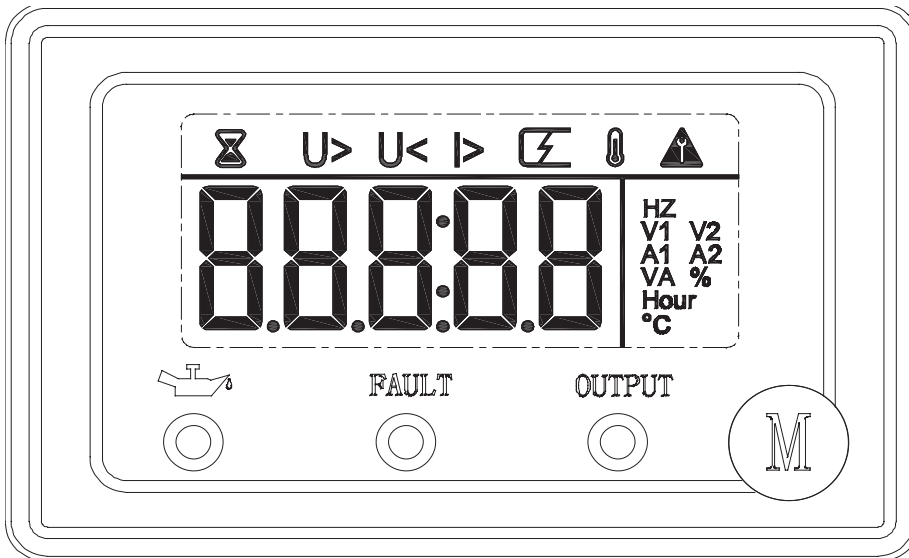



The fuel tap is used to supply fuel from the tank to the carburettor.



Features

Data Display Instrument



-  Normal
-  Short Circuit
-  Over Current
-  Maintenance
-  High volt of AC output
-  High volt DC mother line
-  Low volt of AC output
-  Low volt of DC output
-  MCU high temperature with E3 indicated
-  IGBT high temperature with E4 indicated
-  Low oil when yellow light on
- FAULT** Defects or overloads when red light on
- OUTPUT** Normal running when green light on
-  Mode selections: V1 → A1 → V2 → A2 → VA → Total Running Time → Current Running Time

Contact Us

21

Wiring Diagram

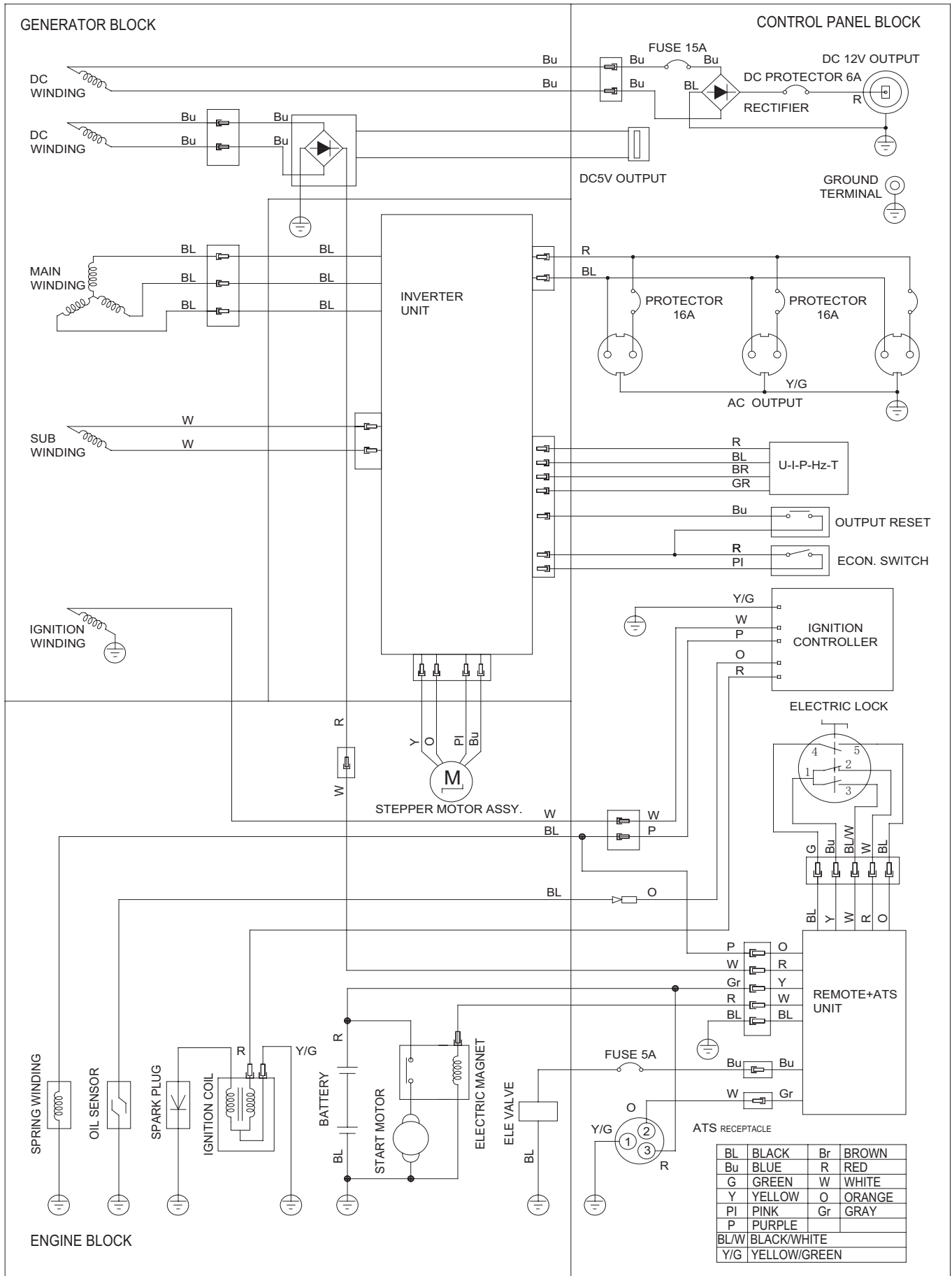

Unboxing

⚠ Unboxing Safety

⚠ **WARNING!** Unboxing and assembling the machine should be done on a flat, stable surface with enough room. Disposal of the packaging should be done in accordance with the local regulations in force.

Carefully remove the product from the packaging and examine it for any sign of damage caused during shipping. Lay the contents out and check them. If any part is damaged or missing, you must not use the machine. Contact HYUNDAI Power Products immediately. You must keep the packaging material in case the machine needs to be returned or repaired.

⚠ **WARNING!** Some of the packaging material may be harmful to children. Keep out of reach of children.

Ensure that you have all the accessories and tools you need for assembly and operation including the suitable personal protective equipment.

Box Contents

- User Manual
- HY6500SEi

We recommend that you fill out the information on page 55. If you need to contact an authorised dealer or customer service for information on servicing, you may need to provide this information.

There is also a service record so you can keep track of your machine service dates.



Pre-Operation Check

 Pre-operation checks should be made each time the generator is used.

Check Engine Fuel

NOTE - The machine is delivered without petrol. All machines are tested and inspected so there may be some residual petrol left in the machine so please fill with caution.



Make sure you read the fuel safety section before handling fuel.

- Make sure there is sufficient fuel in the tank.
- If fuel is low, refill with unleaded petrol.
- Be sure to use the fuel filter screen on the fuel filter neck.
- Recommended fuel: Unleaded petrol.
- Fuel tank capacity: 18.5L

WARNING

- Do not refill tank while engine is running or hot.
- Close fuel cock before refuelling with fuel.
- Be careful not to admit dust, dirt, water or other foreign objects into fuel.
- Do not fill above the top of the fuel filter or it may overflow when the fuel heats up later and expands.
- Wipe off spilt fuel thoroughly before starting engine.
- Keep open flames away.

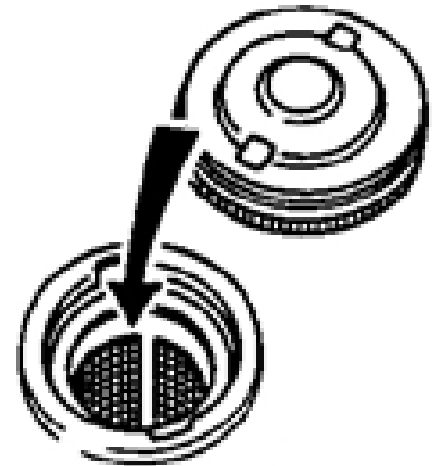
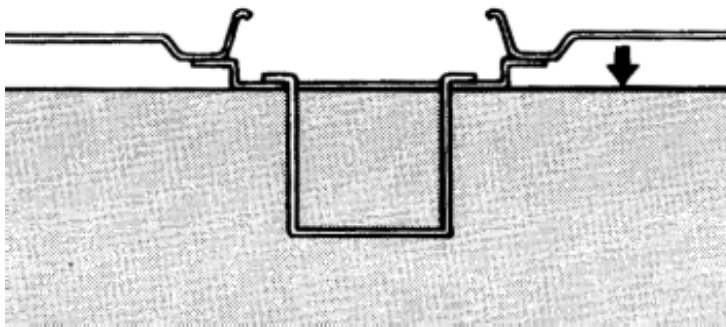
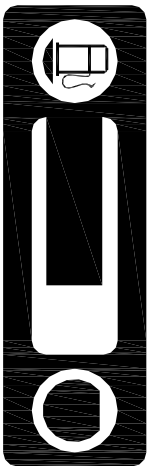

Pre-Operation Check

Check Engine Oil

NOTE - The machine is delivered without oil in the engine. All machines are tested and inspected so there may be some residual oil left in the machine so please fill with caution.

Make sure the engine oil is at the upper level of the oil filler hole. Add oil as necessary.

- Remove oil filler cap and check the engine oil level.
- If oil level is below the lower level line, refill with suitable oil to upper level line. Do not screw in the oil filler cap when checking oil level.
- Change oil if contaminated, or after 100 hours use.

Oil Type : SAE 30 or 15w40 Engine Oil
Oil Capacity : 1.1L

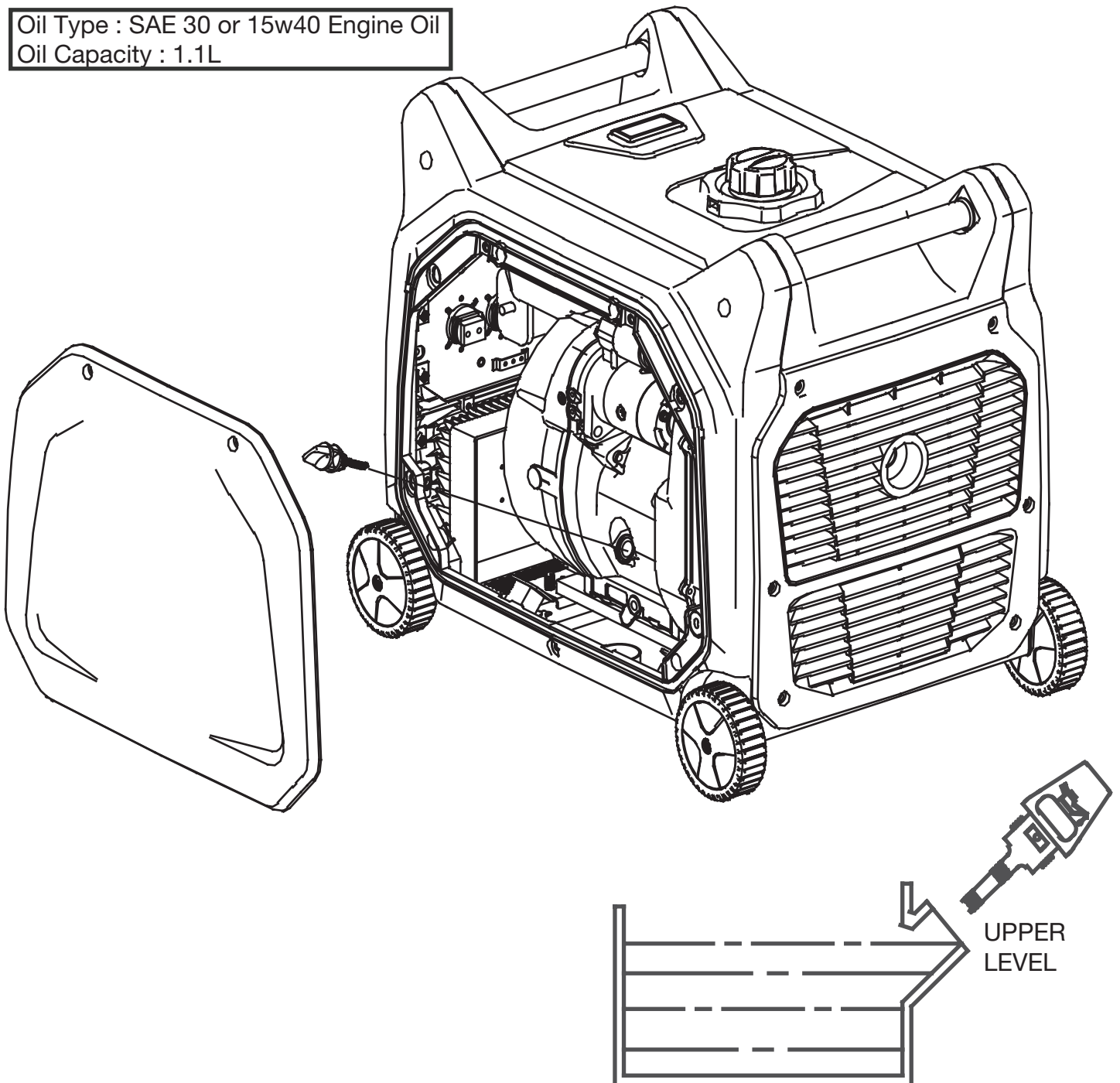

Pre-Operation Check

Ground (Earth)

- Be sure to ground (earth) the generator.

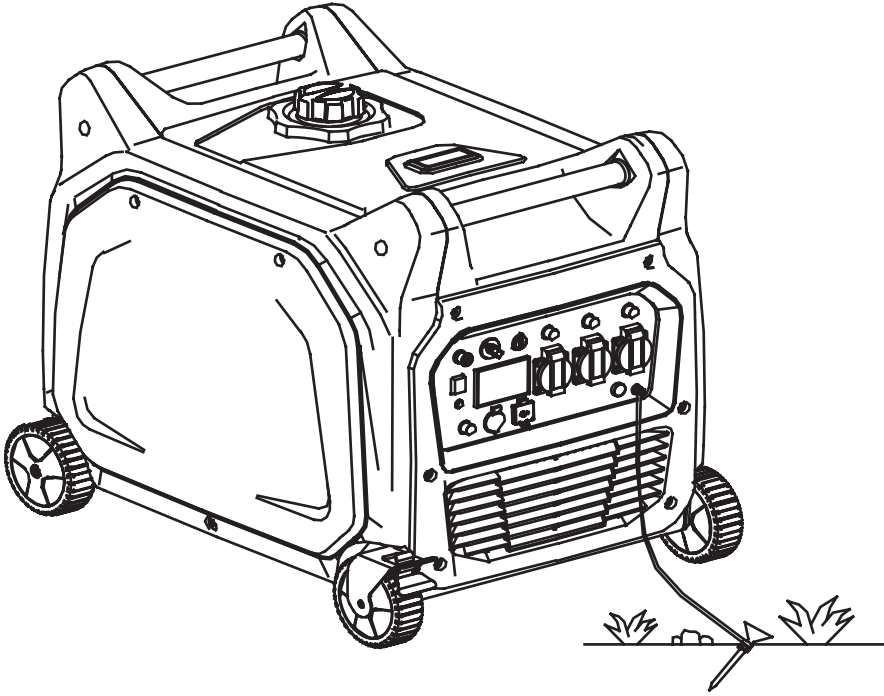

Connect Battery

- Loosen the screw and remove the battery cover.
- Clamp the red wire to the positive (+) terminal and the black wire to the negative (-) terminal of the battery. Do not reverse these positions.
- Be sure the battery is installed on the battery mount tray securely.
- Install the cover and tighten the screw.
- **Recommended Battery : 12V18AH.**

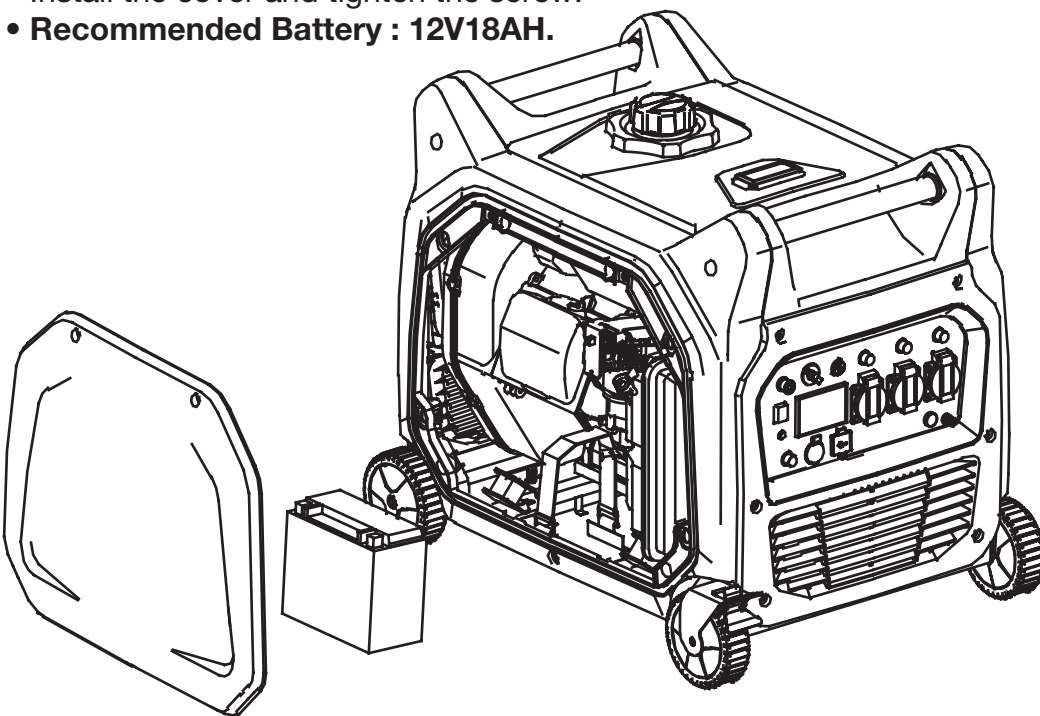

Before Each Use

Before Each Use Checks

⚠ YOU MUST read and understand the full safety instruction manual before starting the machine.

⚠ CAUTION - For OUTDOOR use ONLY. Petrol machines produce carbon monoxide – poisonous, colourless and odourless gas that can cause serious injury or death. Petrol is highly flammable, always handle with extreme care and in a well ventilated area.

- 1 Always ensure that the machine is in a safe working condition. Inspect and check safety devices and guards and check all nuts, bolts and screws are secure.
- 2 Check the oil level and fill the fuel tank.
- 3 Make sure you know how to stop the machine and ensure you are familiar with emergency stop.
- 4 Start the machine following the instructions.



Operation

Starting The Engine

! The generator has been shipped without oil. Fill with oil or it will not start. Do not tilt the generator when adding engine oil. This could result in overfilling and damage to the engine.

! Before starting the engine, do not connect the electric apparatus.

A) Electric Start

- 1 Turn the fuel tap to the ON position.

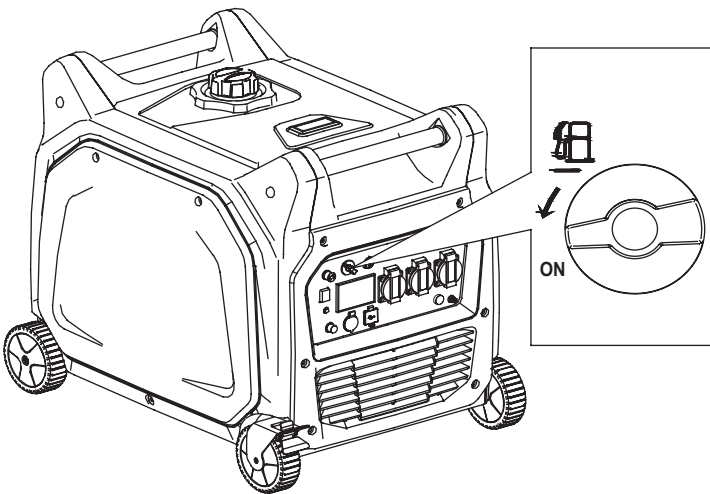

- 2 Turn the engine switch to the START position until engine starts.

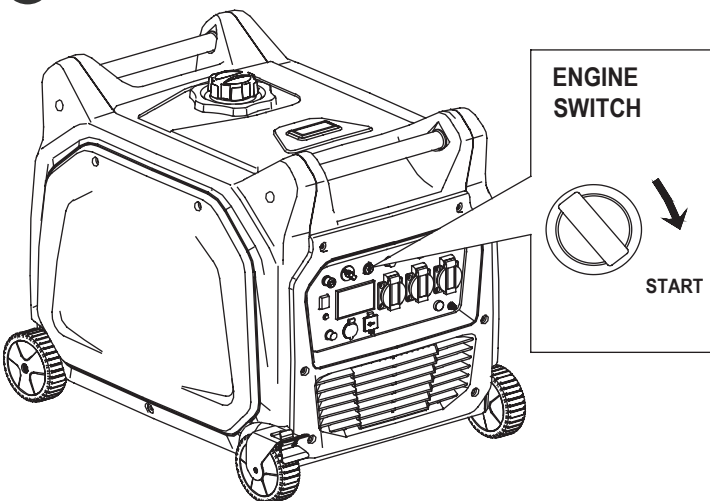

Operation

- 3 Release the engine switch to the RUN position.

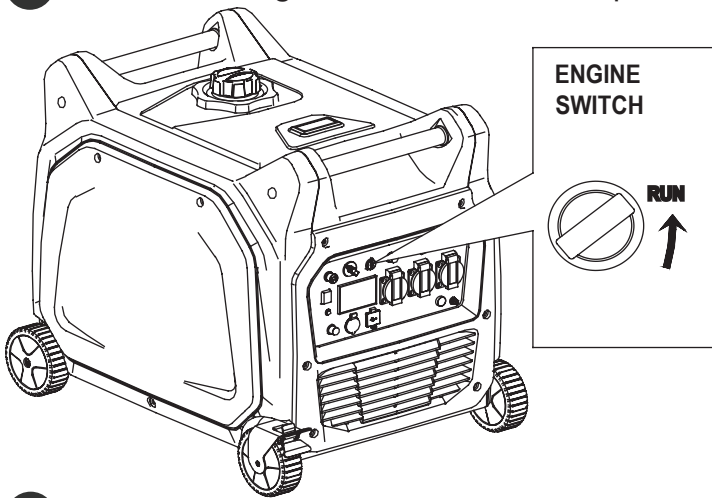

- 4 Warm up the engine without any load for a few minutes.

B) Remote Start

- 1 Please make sure the fuel shutoff valve to the ON position, the engine switch to the RUN position.
- 2 Press the  button on the remote control (key fob) twice.
- 3 Please wait 10 seconds and repeat again if it didn't start.
- 4 Warm up the engine without a load for a few minutes.

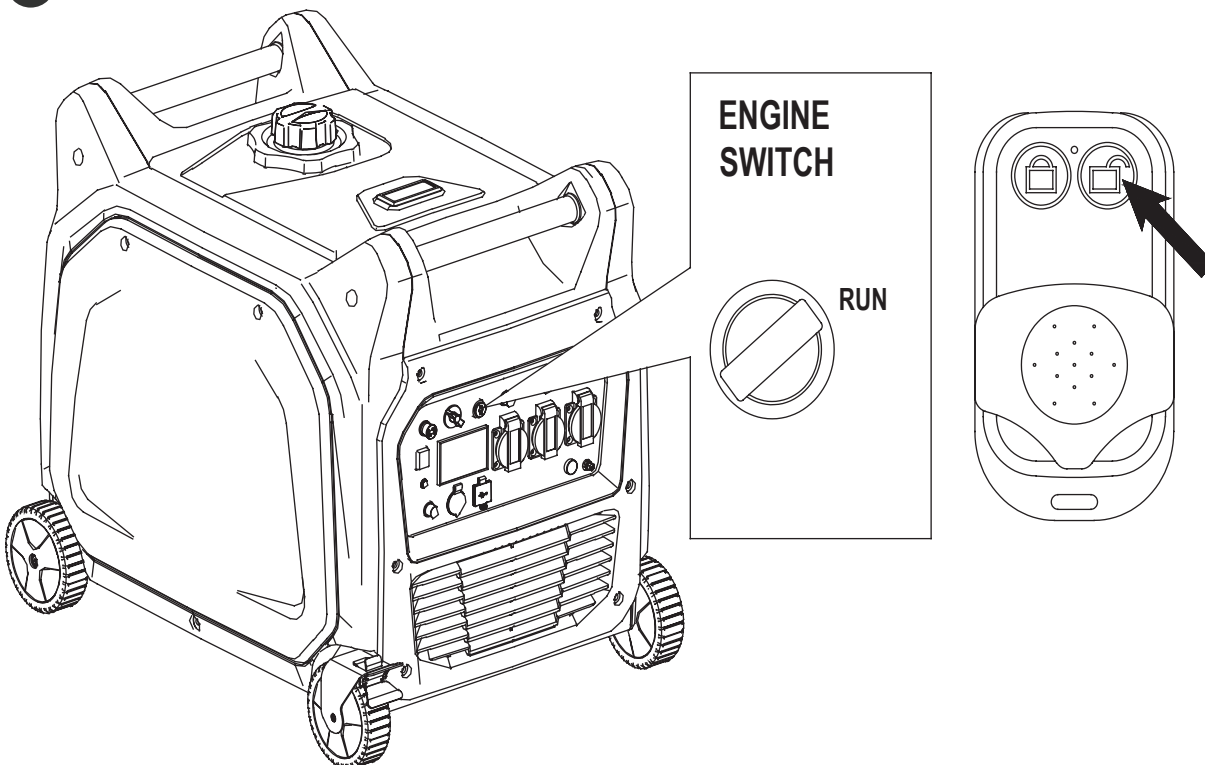

Contact Us

Operation

Using Electric Power

AC Application

- 1 Check the AC pilot lamp for correct voltage.
- 2 Turn off the switch(es) of the electrical appliance(s) before connecting to the generator.
- 3 Insert the plug(s) of the electrical appliance(s) into the sockets.

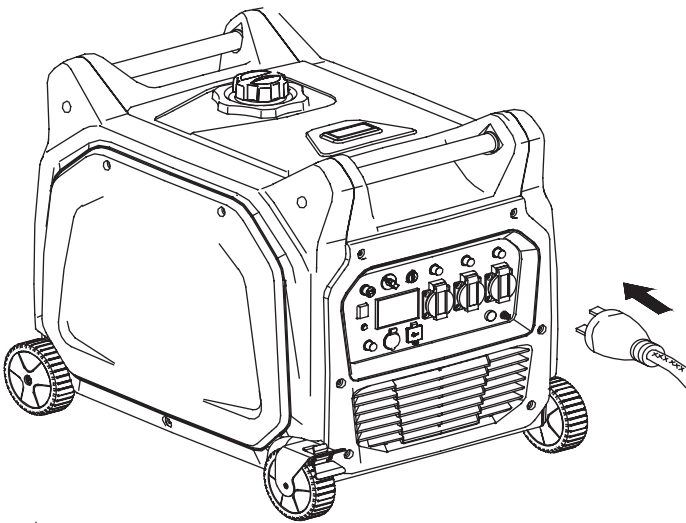

! WARNING

- Be sure the electric apparatus is turned off before plugging in.
- Be sure the total load is within generator rated output.
- Be sure the socket load current is within socket rated current.
- The economy control switch must be turned to OFF when using electric devices that require a large starting current, such as a compressor or a submersible pump.

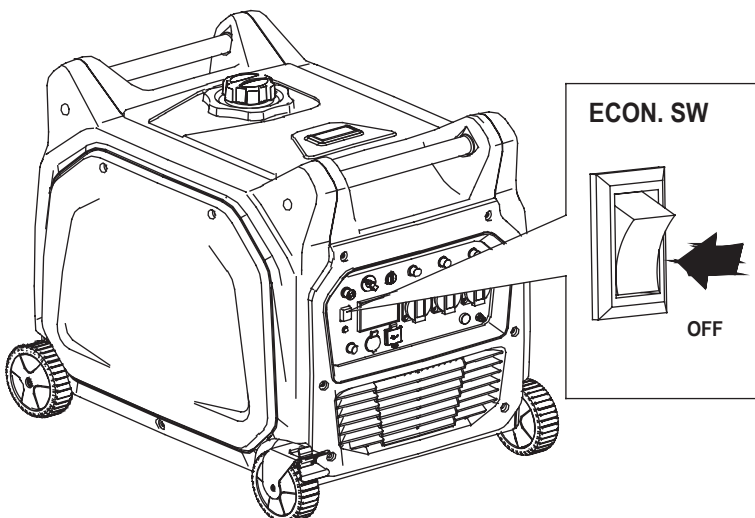

Operation

Overload Indicator Light

The overload indicator light comes on when an overload of a connected electrical device is detected, the inverter unit overheats, or the AC output voltage rises. The electronic breaker will then activate, stopping power in order to protect the generator and any connected electric devices. The overload indicator light (red) will turn on, then the generator will stop output. If so please follow the following steps:

- 1 Turn off any connected electric devices.
- 2 Reduce the total wattage of connected electric devices within the application range.
- 3 Check for blockages in the cooling air inlet and around the control unit. If any blockages are found, remove.
- 4 After checking, push output reset.

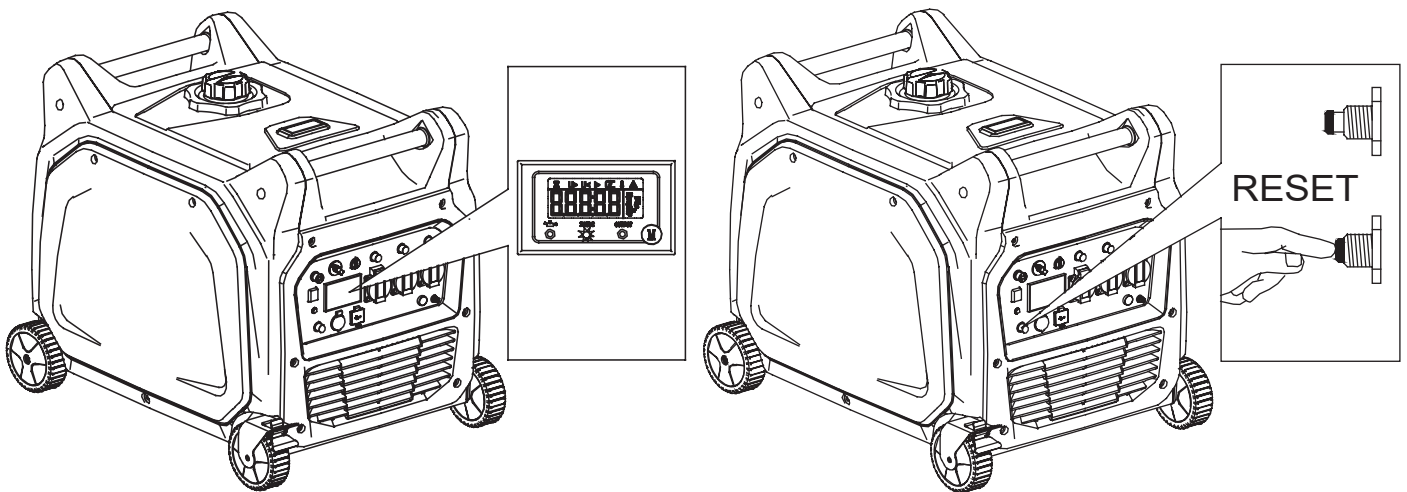

! WARNING

- The generator AC output automatically resets when the engine is stopped and then restarted.
- The overload indicator light may come on for a few seconds at first when using electric devices that require a large starting current, such as a compressor or a submersible pump. However, this is not a malfunction.

Operation

DC Application (Option)

This usage is applicable to 12V battery charging only.

- 1 Charging instruction for battery.
 - Disconnect the leads for the battery.
 - Loosen the battery fluid filler cap.
 - Fill distilled water to the upper limit, if the battery fluid is low level.
- 2 Connect between the DC output socket and the battery terminals using the charging leads. The leads shall be connected making sure of the (+) and (-) polarity.
- 3 The DC circuit protector is to be set to ON after confirming the connection, if the protector is in OFF position.

! WARNING

- Be sure the economy control switch is turned off while charging the battery. Do not overcharge the battery.

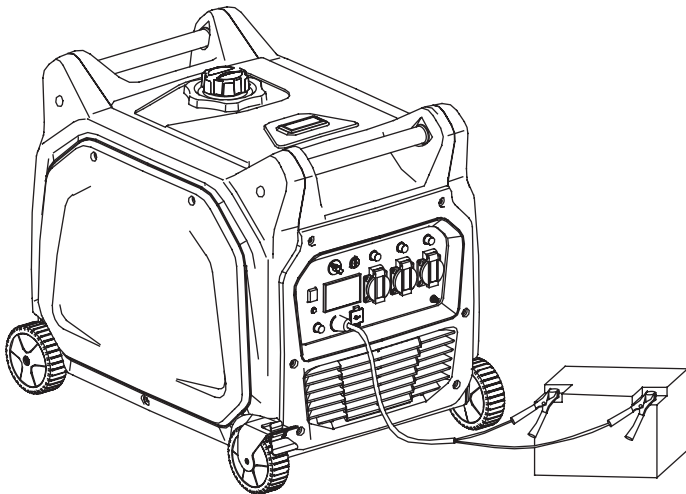

Operation

Stopping The Engine

- 1 Turn off the power switch of the electric apparatus or disconnect any electric devices.

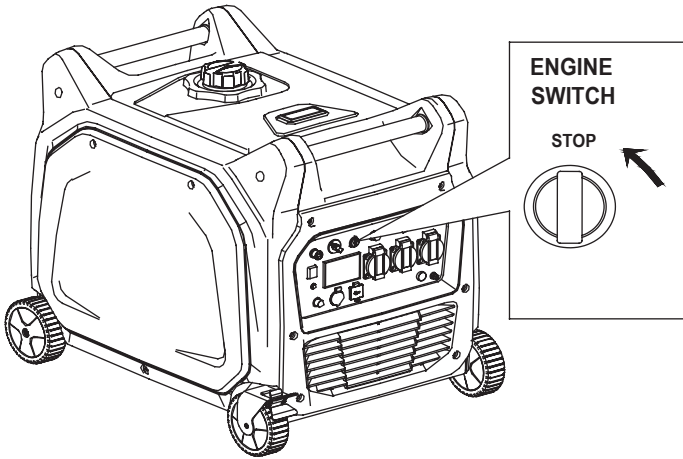

- 2 Turn the engine switch to STOP position. Click remote switch to the  position.

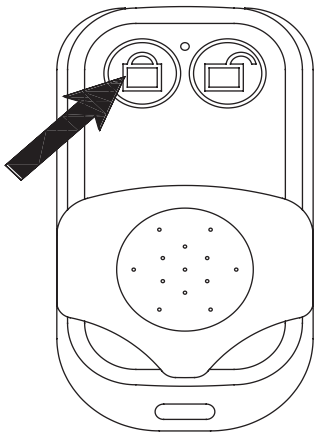

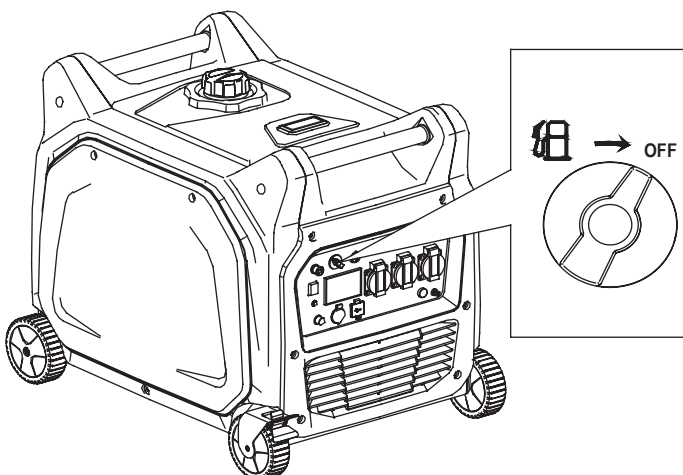

- 3 Turn the fuel cock lever to OFF.





Maintenance

Maintenance Safety

 **IMPORTANT** - Routine and accurate maintenance is essential for maintaining original machine safety and performance levels.

 **WARNING** - Before cleaning or doing maintenance work, you need to stop the engine, and read the relevant instructions. You need to wear proper clothing and protective gloves whenever your hands are at risk.

 If there are worn or damaged parts, never use the machine. Faulty or worn-out parts must be replaced and not repaired. You must only use original spare parts. The use of non-original and/or incorrectly fitted parts will jeopardize the safety of the machine. This may also cause accidents or personal injuries for which the manufacturer is under no circumstance liable or responsible.

 Any maintenance operations or adjustments not explained in this manual must be carried out by your Dealer or a specialised Service Centre with the necessary knowledge and equipment to ensure that the work is done correctly maintaining the machine's original safety level. Any operations performed in unauthorised centres or by unqualified persons will invalidate the Warranty and all obligations and responsibilities of the Manufacturer.

Maintenance

Cleaning

 **CAUTION - DO NOT** use a hose pipe or pressure washer to clean the engine. Water can damage the engine or contaminate the fuel system.

 **NOTE** Engine must be switched off.

- Make sure not to drip petrol onto the plastic parts to prevent damaging them and remove all traces of spilt petrol immediately. The warranty will not cover damage to plastic parts caused by petrol.
- Avoid using solvents when cleaning plastic parts. Most plastics are susceptible to damage from various types of commercial solvents and may be damaged by their use.

Transportation

Whenever the machine is to be handled, lifted, transported or tilted, you must:

- 1 Wear sturdy work gloves.
- 2 Hold the machine at the points that offer a safe grip, taking into account the weight and relative distribution of the same.
- 3 Use an appropriate number of people for the weight of the machine and the characteristics of the vehicle or the place where it must be placed or collected.
- 4 You must make sure that machine movements do not cause petrol leaks, damage or injuries.
- 5 During transport, make sure to fasten the machine securely with cables or straps.
- 6 The machine must be transported on a flat surface.
- 7 Do not run this generator in a vehicle or confined space.

Maintenance

Maintenance Chart

Routine and accurate maintenance is essential for maintaining original machine safety and performance levels.

It is recommended that the following maintenance schedule is followed.

Item	Remarks	Pre-Operation Check (Daily)	Initial 1 Month or 20Hr	Every 3 Months Or 50Hr	Every 6 Months Or 100Hr	Every 12 Months Or 300Hr
Spark Plug	Check condition adjust gap and clean. Replace is necessary.			X		
Engine Oil	Check oil level. Replace.	X	X		X	
Oil Filter	Clean oil filter.				X	
Air Filter	Clean. Replace if necessary.			X		
Fuel Filter	Clean fuel cock filter. Replace is necessary.				X	
Valve Clearance	Check and adjust when engine is cold.					X
Fuel Line	Check fuel hose for crack or damage. Replace if necessary.	X				
Exhaust System	Check for leakage. Re-tighten or replace gasket is necessary.	X				
	Check muffler screen. Clean / replace if necessary.					X
Carburettor	Check operation.	X				
Cooling System	Check fan damage.					X
Starting System	Check recoil starter operation.	X				
Idle Speed	Check and adjust engine idle speed.					X
Fittings / Fasteners	Check all fittings and fasteners correct if necessary.				X	
Crankcase Breather	Check breather hose for cracks or damage. Replace if necessary.					X
Generator	Check the pilot light comes on.	X				

Maintenance

Engine Oil Replacement

- 1 Place the machine on a level surface and warm up the engine for several minutes. Then stop the engine and turn the fuel cock knob to OFF. Turn the fuel tank cap air vent knob clockwise, to OFF.
- 2 Loosen the screw and remove the cover.

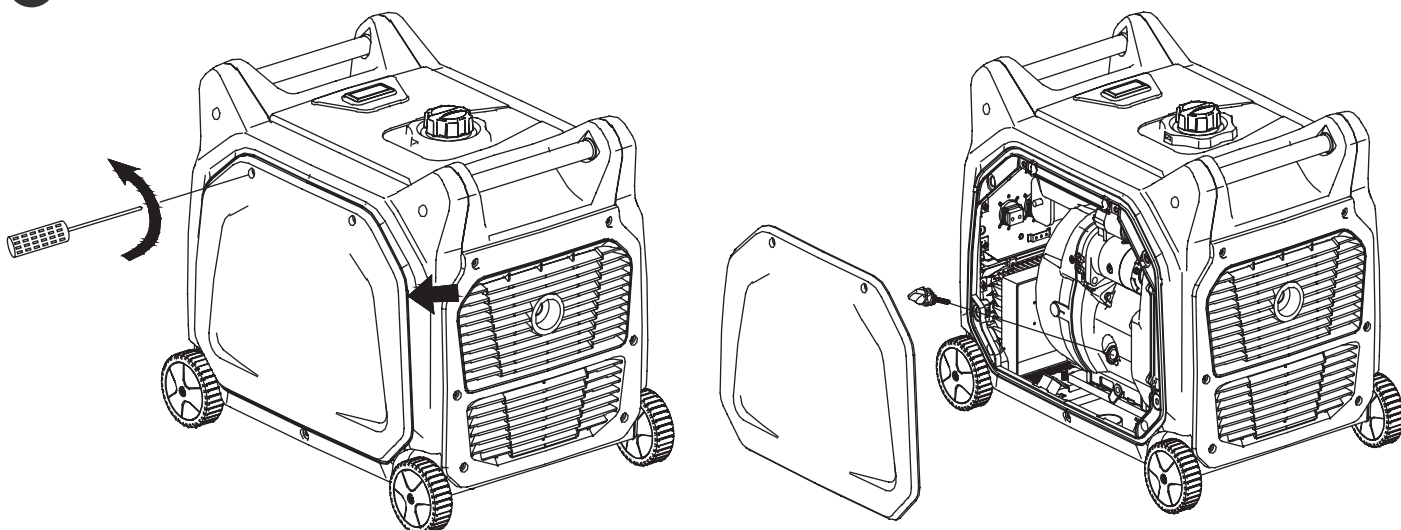

- 3 Remove the oil filler cap and insert tube to drain oil.
- 4 Place an oil pan under the engine. Tilt the generator to drain the oil completely.
- 5 Replace the generator on a level surface.
- 6 Add engine oil to the upper level.

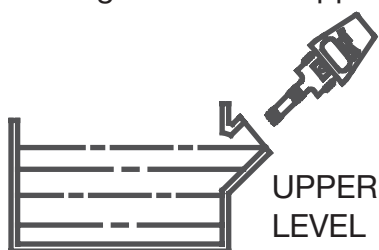

- 7 Install the oil filler cap.
- 8 Install the cover and tighten the screw.

Oil Type : SAE 30 or 15w40 Engine Oil
Oil Capacity : 1.1L

! WARNING

- Be sure no foreign material enters the crankcase.
- Do not tilt the generator when adding engine oil. This could result in overfilling and damage to the engine.
- Clean the oil filter and change oil every other 100hr.

Contact Us



www.hyundaipowerproducts.co.uk



01646 687 880



aftersales@hyundaipowerproducts.co.uk

Maintenance

Air Filter

⚠ CAUTION - A dirty air filter will restrict the air flow to the carburettor, which will reduce engine efficiency. When using the machine in very dusty areas you must clean or replace the air filter more often. Never operate the machine without the air filter being fitted it can cause damage to the engine which is not covered by warranty.

- 1 Remove the cover.
- 2 Remove the air filter cover and element.
- 3 Wash the element in soapy water and dry.
- 4 Oil the element with fresh engine oil and squeeze out excess oil. The element should be wet but not dripping.
- 5 Insert the element into the air filter.
- 6 Refit the cover.

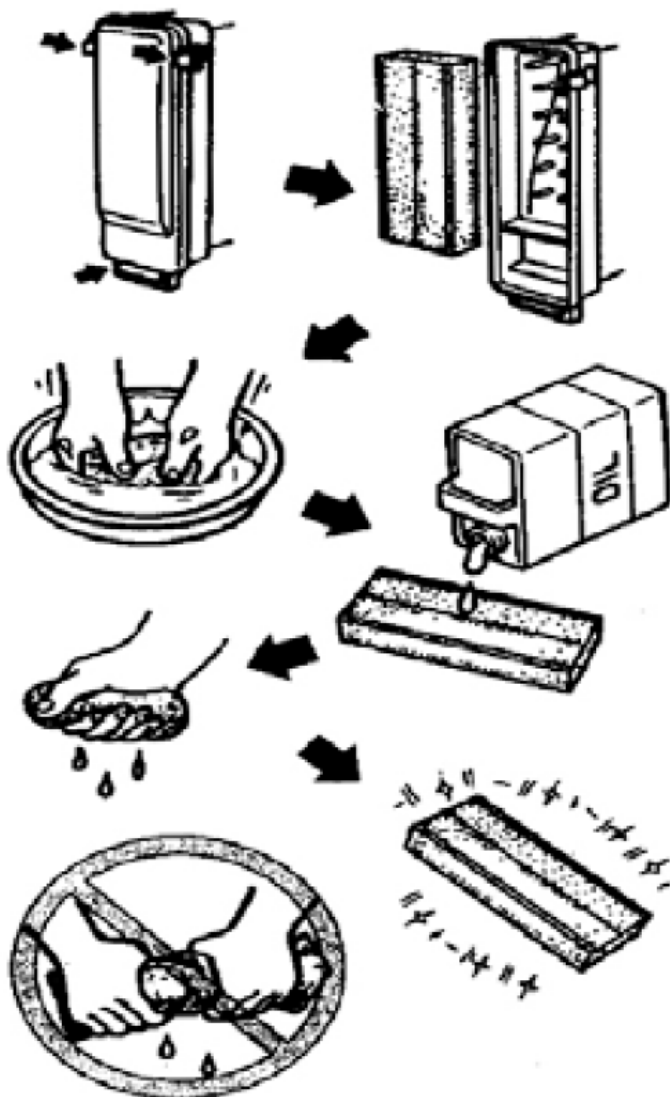

⚠ CAUTION

The engine should never run without the element, excessive piston and/or cylinder wear may result.

Maintenance

Cleaning And Adjusting Spark Plug

For good performance, the spark plug must be properly gapped and free of deposits.

- 1 Remove the cover.
- 2 Check for discolouration and remove any carbon.
- 3 Check the spark plug type and gap.
- 4 Replace the spark plug.
- 5 Install the cover.

Standard electrode colour : Tan colour
Standard spark plug : F6RTC (TORCH)
Spark plug gap : 0.6mm-0.7mm (0.024-0.028in)

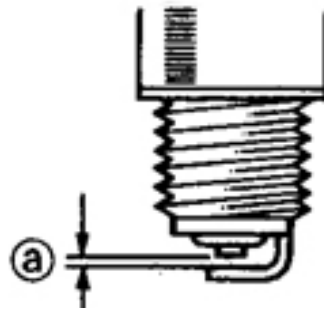
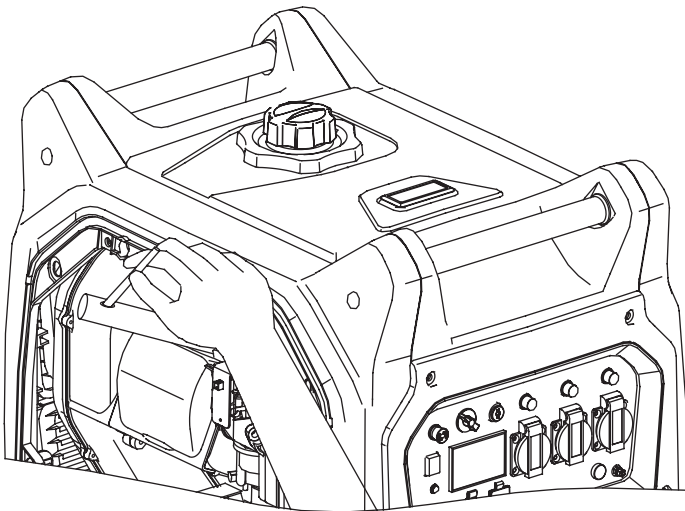

Maintenance

Fuel Tank Filter

- 1 Remove the fuel tank cap and filter.
- 2 Clean the filter with solvent. If damaged, replace.
- 3 Wipe the filter and insert it.

! WARNING

Be sure the tank cap is tightened securely.

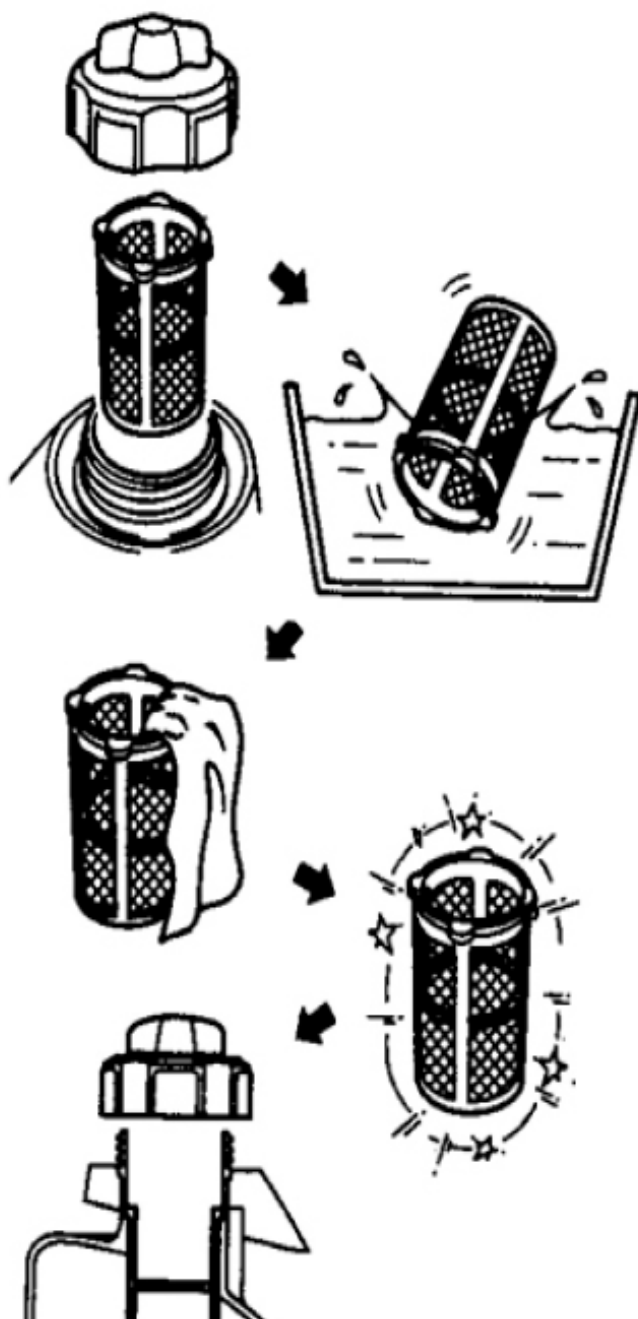

Maintenance

Muffler Screen

! WARNING

- The engine and muffler will be very hot after the engine has been run.
- Avoid touching the engine and muffler while they are still hot with any part of your body or clothing during inspection or repair.

- 1 Remove the cover.
- 2 Remove the muffler screen.
- 3 Use the flat head screw driver to pry the spark arrester out from the muffler.
- 4 Remove the carbon deposits on the muffler screen and spark arrester using a wire brush.
- 5 Install the muffler screen.
- 6 Install the cover.

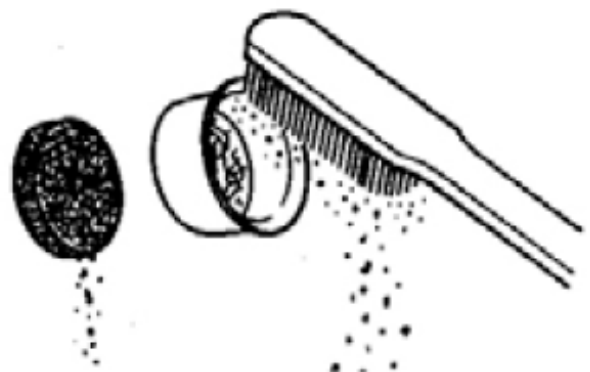
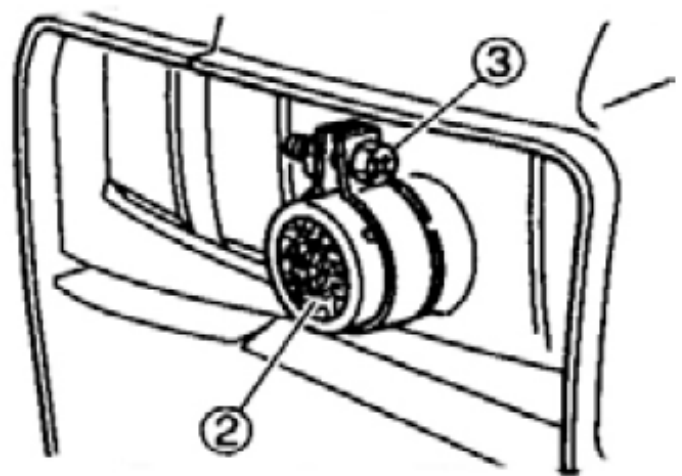
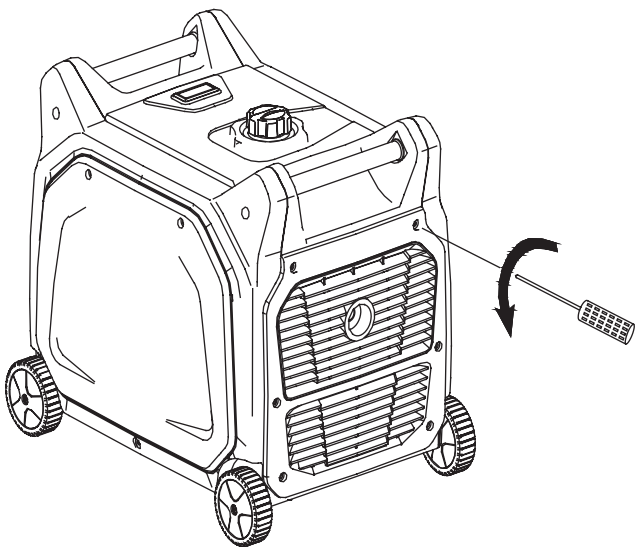







Contact Us

Storage

Storage

Where To Store

-  Store in a cool, dry place away from sources of ignition and varying changes in temperature.
-  Store on a flat and level surface.
-  DO NOT stack other items on top of the machine when in storage.
-  Store the machine in a safe place, out of the reach of children or anyone who is not familiar with operation.
-  DO NOT store the machine with fuel in the tank in an area where the fuel vapours could reach an open flame, a strong heat source or a spark.
-  DO NOT store a machine that has not been given time to fully cool down. Engine must be cooled down fully before storage.

Short Term

After use, please follow the below steps before storing your machine.

- 1 Allow the engine to fully cool down.
- 2 Clean the machine. See the 'Cleaning' section.
- 3 Store the machine following the guidelines above.

Storage

Long Term

If storing the machine for a period of 30 days or more, you must follow proper storage and winterisation guidelines to avoid any possible issues with the machine. Incorrect storage can lead to possible fuelling or engine issues that will not be covered by the warranty.

- 1 Allow the engine to fully cool down.
- 2 Drain all the fuel from the fuel tank. Remove the cover, drain fuel from the carburettor by loosening the drain screw.
- 3 Remove the spark plug, pour in about one tablespoon of SAE30 or 15W40 engine oil in the spark plug hole and reinstall the spark plug.
- 4 Use the recoil starter to turn the engine over several times (with ignition off).
- 5 Pull the recoil until you feel compression.
- 6 Stop pulling.
- 7 Clean exterior of the generator and apply a rust inhibitor.

Preparation To Re-Use

- 1 Check oil level before using.
- 2 Check spark plug is inserted correctly.
- 3 Fill engine with fresh unleaded petrol that has not been stored for periods of more than 30 days.



Troubleshooting

Engine Will Not Start

1. Fuel System

No fuel supplied to combustion chamber.

- No fuel in tank - Supply fuel.
- Fuel in tank - Fuel tank cap air vent knob to ON, fuel cock knob to ON.
- Clogged fuel line - Clean fuel line.
- Clogged carburettor - Clean carburettor.

2. Engine Oil System

- Oil level is too low - Add engine oil.

3. Electrical System

- Spark plug dirty with carbon or wet - Remove carbon or wipe spark plug dry.
- Faulty ignition system - Consult dealer.

4. Compression Insufficient

- Worn out piston and cylinder - Consult dealer.

Generator Will Not Produce Power

- Safety device (AC) to OFF - Stop the engine, then restart.
- Safety device (DC) to OFF - Press to reset the DC protector.

Technical Data

Specifications

Generator	Model	HY6500SEi Inverter Generator
	AC Voltage	230V, 240V
	Frequency	50Hz
	Max. Output	6.6kW
	Rated Output	6kW
	Power Factor	1.0
	DC Output	12V/5.0A 5V/3.1A

Engine	Model	IC390E
	Engine Type	Air-cooled, 4 cycle, OHV petrol engine
	Bore x Stroke	88 x 64
	Displacement	389cc
	Max. Output	7.5kW / 3600rpm
	Fuel	Unleaded petrol
	Fuel Tank Capacity	18.5L
	Rated Continuous Operation	4hr 30min (100% load)
	Lubricating Oil	SAE30 or 15W40
	Lubricating Oil Capacity	1.1L
	Starting System	Electric Starter / Remote Starter
	Ignition System	C.D.I
	Spark Plug Type	F6RTC

Other	Net Dimension (L x W x H)	750 x 537 x 630mm
	Overall Dimension (L x W x H)	825 x 615 x 700mm
	Net Weight	89kg
	Measured Sound Level	73.69dB(A)
	Guaranteed Sound Level	94.76dB(A)

Specifications subject to change without prior notice.

Contact Us



www.hyundaipowerproducts.co.uk



01646 687 880



aftersales@hyundaipowerproducts.co.uk

Technical Data

Spare Parts

Only use original spare parts: The use of non-original and/or incorrectly fitted parts will jeopardize the safety of the machine, may cause accidents or personal injuries for which the Manufacturer is under no circumstance liable or responsible.

Part	Part Number
Wheel	HY6500SEiWHEEL
Spark Plug	HY6500SEiSPARKPLUG
Air Filter	HY6500SEiAIRFILTER
Recoil Starter	HY6500SEiRECOILSTARTER
Engine Oil SAE 30 or 15W40	600MLSAE30OIL

Declaration Of Conformity

EC Declaration of Conformity

We hereby declare that the machine detailed in this declaration complies to all the relevant provisions of the following EC directives.

- 2006/42/EC The Machinery Directive
- 2014/30/EU Annex II Electromagnetic Compatibility Directive
- 2016/1628/EC The Emission of Gaseous and Particulate Pollutants from internal Combustion engines
- 2000/14/EC Noise Emissions in the Environment by Equipment for use Outdoors.

And is in conformity with the applicable requirements of the following documents:

- EN ISO 8525 13A
- EN ISO 8528-13:2016
- EN ISO 8528-10:1998

Declaration for 2000/14/EC Noise Emissions in the Environment by Equipment for use Outdoors.

Notified Body for EC Directive 2000/14/EC- Intertek Testing Services Hangzhou

Model	Type	Maximum Output	Measured Sound Power	Guaranteed Sound Power	Rated Output
HY6500SEi	Petrol generator	6.6kW	73.69dB(A)	94.76dB(A)	6.0kW

Product Details:

Brand: Hyundai

Model: HY6500SEi

Description: Petrol generator

Name and address of technical documentation holder and EU distributor:

Genpower Ltd, Isaac Way, Pembroke Dock, Pembrokeshire, SA72 4RW, UK.

Signed by: 

Roland Llewellyn, Managing Director

Date: 01/07/2020

Contact Us



www.hyundaipowerproducts.co.uk



01646 687 880



aftersales@hyundaipowerproducts.co.uk

Recycling And Disposal

Recycling And Disposal



We do not offer a takeback scheme for the recovery of Waste Electrical Electronic Equipment (WEEE) & Batteries. Instead the responsibility to dispose of WEEE and/or Batteries is passed onto you by us.

So when it becomes necessary to dispose of your machine you must take it to your local Civic Amenity Site. For further information please contact your local Authority for disposal advice.

You **MUST** make sure that all unused oil and fuel is disposed of correctly either beforehand or at your local Civic Amenity Site.

- Under NO circumstances must any fuel or oil be put down any drains.
- Certain products contain WEEE waste which should not be disposed of in your domestic waste.
- You **MUST** recycle WEEE in accordance with your local authority or recycling centre.
- Certain products contain batteries which should not be disposed of in your domestic waste.
- You **MUST** recycle batteries in accordance with your local authority or recycling centre.
- Unwanted packaging and materials should be stored and taken to a recycling centre so it can be disposed of in a manner which is compatible with the environment.

We are a Member of the VALPAK National Compliance Scheme and our registration number is **RM08660**. For further information about disposal please contact your Local Authority.

You can also get more advice and guidance about recycling at the following website
<http://www.recycle-more.co.uk>

Should you pass this product on to another user either sold or loaned, you **MUST** pass on this user manual. This will make sure that all other users can use and maintain this machine safely.

Environmental Protection

1. Environmental protection should be a priority of considerable importance when using the machine, for the benefit of both social coexistence and the environment in which we live. Try not to cause any disturbance to the surrounding area.
2. You must comply with local regulations and provisions for the disposal of packaging, oils, petrol, filters, damaged parts or any elements which have a strong impact on the environment. This waste must not be disposed of as normal waste. It needs to be separated and taken to specified waste disposal centres where the material will be recycled.
3. You must comply with local regulations for the disposal of waste materials after mowing.
4. When disposing, do not pollute the environment with the machine, but hand it over to a disposal centre, in accordance with the local laws in force.

Notes

Our Product Range

Generators

Leisure Inverter, Petrol, Diesel And Built-In Motorhome Generators

Pressure Washers

Petrol, Diesel And Electric Pressure Washers

Water Pumps

Submersible, Clean And Dirty Water And Professional Chemical Water Pumps

Lawnmowers

Petrol, Cordless, Electric, Roller, Self Propelled, Electric Start And Robotic Lawnmowers

Grass Trimmers And Brush Cutters

Petrol, Cordless, Electric And Wheeled Grass Trimmers And Brush Cutters

Chainsaws

Petrol, Cordless And Electric Chainsaws

Hedge Trimmers

Petrol And Cordless Hedge Trimmers

Leaf Blowers

Petrol, Electric, Cordless, Backpack And 3 -in-1 Leaf Blowers

Log Splitters

Horizontal, Vertical, Petrol And Electric Log Splitters

Wood Chippers

Petrol And Electric Start Wood Chippers

Tillers

Petrol Garden Tiller And Cultivator

Earth Augers And Trenchers

Petrol Earth Augers And Heavy Duty Trenchers

Compactor Plates

Petrol Compactor Plates

Cement Mixers

Portable Electric Cement Mixers

Mini Dumpers

4-Wheel Drive Mini Dumpers And Tracked Dumpers

Yard Sweeper

Self Propelled Yard Sweeper Power Brush

Scarifiers

Petrol Lawn Scarifier And Aerator

Stump Grinders

Petrol 4-Stroke Stump Grinders

Welders And Plasma Cutters

MIG, TIG, MMA, ARC Welders And Plasma Cutters

Power Tools And Tool Chests

Electric And Cordless Power Tools And Filled Tool Chests

Vacuum Cleaners

Wet And Dry Vacuum Cleaners

Engines

Petrol And Electric Start Engines

Battery Chargers / Starters

6V, 12V, 24V Battery Chargers, Jump Starters And Hydraulic Floor Jack

Air Compressors

Home, Domestic, DIY And Professional Use Air Compressors

Lighting Towers

Mobile Lighting Towers With Diesel Generators

Portable Power Stations

Camping Power Packs And Solar Chargers

And More

We Are Constantly Expanding Our Range With New Products

If you would like more information on any of these products, please contact our sales team on 01646 687880 or visit our website www.hyundaipowerproducts.co.uk

Useful Information

Check Out Our YouTube Channel

Our videos on YouTube include:

- Unboxing
- Assembly of your machine
- How to service your machine
- Products in use
- 'How To' videos
- Product features

Go to www.hyundaisupport.co.uk or search 'Hyundai Power Products' in YouTube.

Warranty

Proof of purchase will be required before you make a warranty claim.

Full warranty terms and conditions can be found on the HYUNDAI POWER PRODUCTS website: www.hyundaipowerproducts.co.uk

Manual Updates

Our manuals are constantly being reviewed and updated. Should you find an error, omission or something unclear, please contact us for assistance.

We reserve the right to make any modifications without prior notice whenever necessary.

Our latest manuals are also placed online.

All our manuals can be downloaded at: www.hyundaipowerproducts.co.uk

Returning Your Product

If you are returning your product, please contact the dealer for their returns policy.

Leaving A Review

We work very hard to give all of our customers the best possible service. If you have any problems, before leaving negative feedback, please contact us to give us a chance to resolve the issue. We would be delighted if you left us positive feedback!

To leave a review, please go to: uk.trustpilot.com/review/hyundaipowerequipment.co.uk

Ordering Spare Parts

Only use original spare parts: The use of non-original and/or incorrectly fitted parts will jeopardize the safety of the machine, may cause accidents or personal injuries for which the Manufacturer is under no circumstance liable or responsible.

Contact Us



Need Help? Talk To Our Experts

Contact Us

Our friendly aftersales team will be more than happy to help you.

Phone

Call our team on 01646 687880, open Monday-Friday 8.30am-5pm.

Email

aftersales@hyundaipowerproducts.co.uk

Online Live Chat

Go to www.hyundaipowerproducts.co.uk

Live chat is open Monday-Friday from 8.30am-5pm.

Post

Genpower Limited, Isaac Way, Pembroke Dock, Pembrokeshire, SA72 4RW, UK.

Product Information

Information

As soon as you have purchased the machine, we recommend that you fill out the following. If you need to contact an authorised dealer or customer service for information on servicing, you may need to provide the following information.

The model number and serial number can be found on the grey specification sticker on your machine.

Date Of Purchase:

Dealer Name:.....

Dealer Phone:.....

Model Number:.....

Serial Number:.....

Service Record

1st Service

Date Of Service.....

Next Service Due.....

2nd Service

Date Of Service.....

Next Service Due.....

3rd Service

Date Of Service.....

Next Service Due.....

4th Service

Date Of Service.....

Next Service Due.....

Contact Us



www.hyundaipowerproducts.co.uk



01646 687 880



aftersales@hyundaipowerproducts.co.uk

HYUNDAI

POWER PRODUCTS

Importer:
GENPOWER LTD
Isaac Way, London Road,
Pembroke Dock, UNITED KINGDOM, SA72 4RW
T: +44 (0) 1646 687 880 F: +44 (0) 1646 686 198
E: info@hyundaipowerproducts.co.uk
www.hyundaipowerproducts.co.uk

Imported/Distributed by Genpower Ltd for The United Kingdom & Ireland

Licensed by Hyundai Corporation, Korea